

Pneumatic control for robotics and industrial automation

Author: Naresh Raghavan

Introduction

Pneumatic systems form the most primitive and distinct class of mechanical control engineering. They are classified under the term 'Fluid Power Control', which describes any process or device that converts, transmits, distributes or controls power through the use of pressurized gas or liquid. When high-pressure liquids (like oil) are used to transmit power, the system is termed as *hydraulics*. In a pneumatic system the working fluid is a gas (mostly air) which is compressed above atmospheric pressure to impart pressure energy to the molecules. This stored pressure potential is converted to a suitable mechanical work in an appropriate controlled sequence using control valves and actuators.

Pneumatic systems are well suited for the automation of a simple repetitive task. The working fluid is abundant in nature and hence the running and maintenance cost of these systems are exceptionally low. All fluids have the ability to translate and transfigure and hence pneumatic systems permit variety of power conversion with minimal mechanical hardware. Conversion of various combinations of motions like rotary-rotary, linear-rotary and linear-linear is possible. The simplicity in design, durability and compact size of pneumatic systems make them well suited for mobile applications. These features make them versatile and find universal applications including robotics, aerospace technology, production and assembly of automotive components (power steering, chassis and engine assembly), CNC machines, food products and packaging industry, bomb deployment units and fabrication process of plastic products.

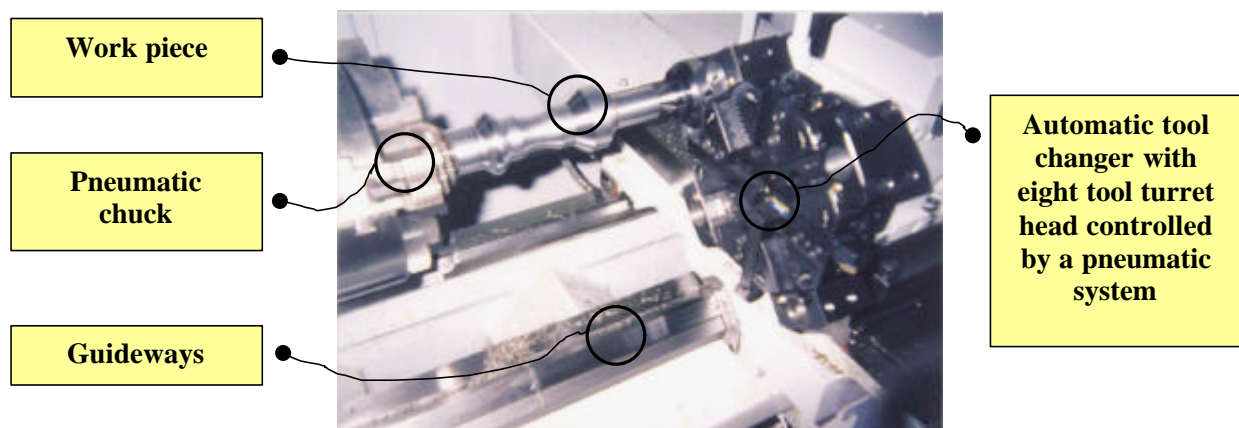

In a CNC Lathe, the indexing of the tool is achieved by using the Automatic Tool Changer (ATC) having the capacity to hold 8 tools simultaneously, which facilitates the machine to be programmed to perform 8 different operations without manual intervention for tool changes. The indexing of the ATC is performed by a closed loop pneumatic system, which is controlled by an onboard computer. The CNC part program entered by the operator specifies the direction of motion and the required tool. The post processor decodes the program instruction and issues appropriate commands to the pneumatic controller to index the ATC in order to position the required tool for the subsequent operations.

The pneumatic saw is a semi-automatic machine powered by an open loop controlled pneumatic system. It is used to cut wooden planks, plastic sheets and pipes. This machine was custom designed and carries the pride of increasing production by 35% for a very low investment and maintenance cost.

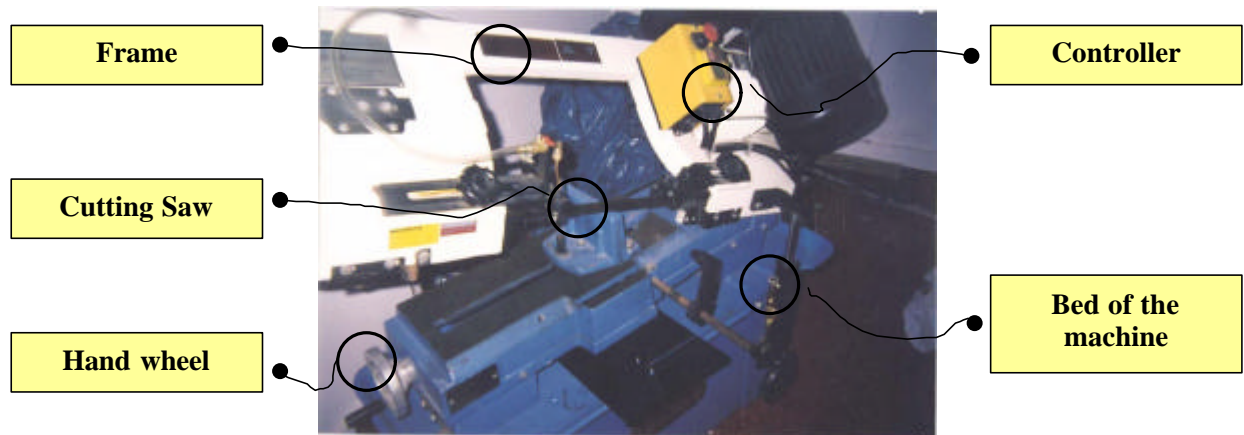

Pneumatic systems used in broaching, drilling and gear shaper machines are controlled by a Programmable Logic Controller (PLC) which reduce the cycle time during production. Traditional pneumatic system does not have a PLC or any electrical/electronic controllers. Rugged mechanical controllers incorporating the logic circuits and flip-flops were used. The designs of such controllers were complex and required in-depth knowledge in mathematics, mechanics and control theory. But once the system works it never failed. The electronics industry has replaced these traditional controllers with solid state devices, Programmable Logic Array (PLA), PLC, microprocessors and state of the art microcontrollers, creating machines with silicon brain and stalwart brawn.

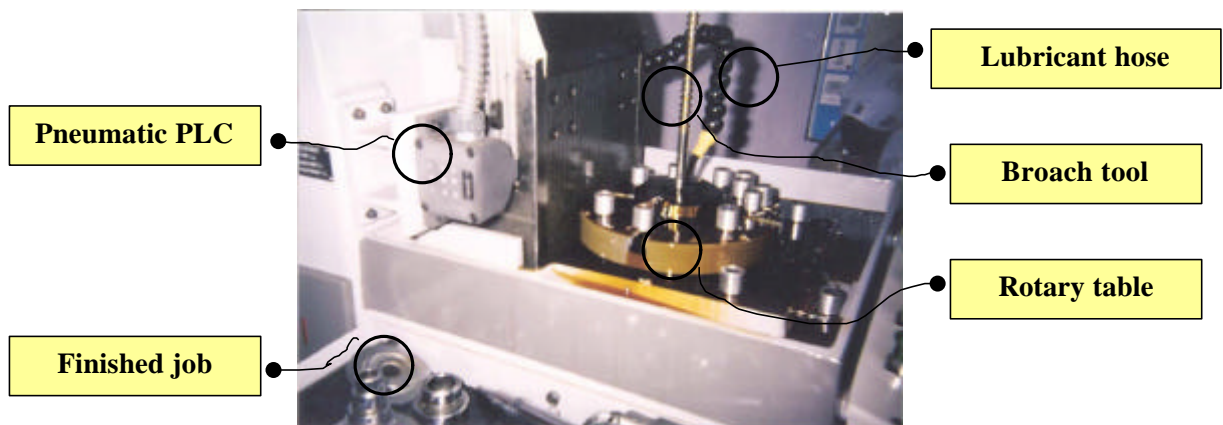

The above examples illustrate some of the applications of pneumatic systems in manufacturing industries. Assembly of manufactured components is performed using pneumatic robots. Some of the automotive industries have sophisticated robot assembly lines where vehicles roll out for testing, untouched by human hands.

Generalized pneumatic system

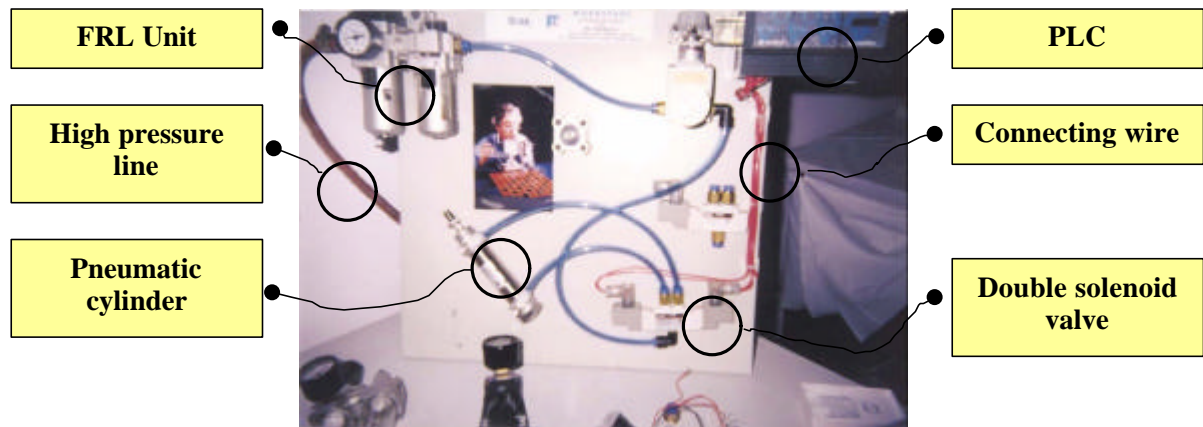

The generalized pneumatic system consists of an air compressor, which delivers air to a pressure reservoir (accumulator). High-pressure line is tapped from the reservoir and fed to the Filter-Regulator-Lubricator (FRL) unit where the air is filtered, lubricated and the pressure is regulated. The air from the outlet of the FRL unit enters the relief valve, which protects the system and bleeds air to atmosphere if the working pressure exceeds the safe preset value. The pressure gauge mounted on the relief valve is used to monitor the working pressure of the system. Flexible hoses connect the outlet port of the relief valve and the inlet port of a pneumatic Direction Control Valve (DCV). This valve can be actuated mechanically, manually, or by electrical solenoids. A pneumatic PLC controls the valve using the solenoid. When the left solenoid of the DCV is energized by the PLC, the piston in the pneumatic cylinder (actuator) moves outward and energizing the right solenoid cause the piston to move inward. The piston stops when both the solenoids are de-energized. This process is a timer-based control in the PLC. The generalized pneumatic system can be represented using the Fluid Power Diagrams and graphical symbols shown below. (Refer Appendix for the symbol list)

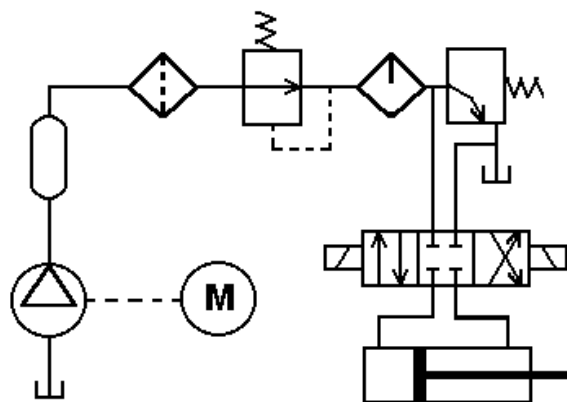

Components of a pneumatic system

Air compressor – The air compressor is the chief source of pressure energy in a pneumatic system. A simplified compressor has two ports – suction and delivery and a piston-cylinder assembly where the piston is coupled to a rotating crank. When the crank is rotated by means of an electric motor or heat engine, the piston reciprocates inside the cylinder. During the inward (suction) stroke, air enters the chamber and during the outward (delivery) stroke, the air is compressed and exhausts through the delivery. This type of compressors is called as positive displacement reciprocating type. There are various types like vane type rotary compressor, turbo compressor, multistage compressor etc., which are selected based on the exit pressure and the volume of air required for the application.



FRL units

FRL unit – Air used in pneumatic systems must be free from dust particles and treated before admitting into the other components. The FRL unit performs three essential functions. The air is filtered and the working pressure is regulated. The clean air is then mixed with fine particles of oil (atomization) before using it for practical purpose. The oil acts as lubricant and deposits on the walls of the valves and actuators thus reducing friction between the piston and the walls of the cylinder. It also acts as a sealant preventing minor leakage during operation.

Relief valve – The relief valve is the most important pressure-limiting device. A simple relief valve consists of a spring-loaded spool, which is displaced from its normal position when the working pressure exceeds the set value. This causes an opening of an orifice, venting the excess flow to the atmosphere.

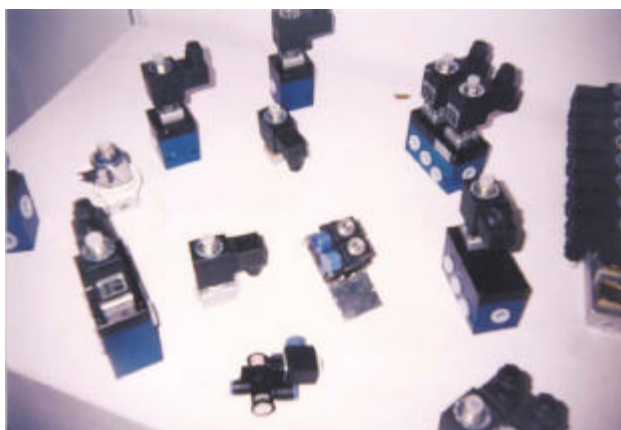

Relief valves, Pilot operated check valves and flow control valves

Under safe operating conditions the spring force closes the valve. The restoring force of the spring can be varied to set different working pressure.

Check valve – A check valve permits the flow of fluid in a single direction only and closed itself to prevent the flow in opposite direction. The check valve consists of a spring-loaded ball, which is lifted from its seat to permit flow, and when the pressure is reversed, the ball is forced against the seat causing the flow to cease. To permit flow in the reverse direction a pilot operated check valve is used where a piston operated by the pilot pressure displaces the ball from the seat.

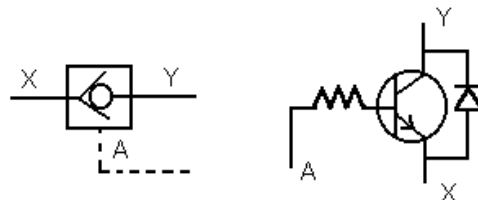

When X is at a higher pressure than Y flow takes place. When Y is at a higher pressure than X there is no flow unless a certain amount of pilot pressure is applied at A. An equivalent electrical circuit is shown to explain the operation of a pilot check valve.

Flow control valve - Flow control valve consists of an orifice through which the flow of air is restricted. It is used to impede free flow through a section of the pneumatic system. Variable flow control valves are used to vary the impedance caused to free flow across a passage.



Solenoid actuated and manually actuated pneumatic direction control valves

Direction control valve (DCV) - DCVs are used to control the direction of flow of fluid through a pneumatic system. There are various types of DCVs based on number of ports and number of positions of operation. A simple 2 port - 2 position valve (2/2 valve) is represented as below.

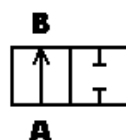

The two boxes represent the two possible position of the valve. In the first position, the arrow indicates that the two ports A and B are connected and flow can take place from A to B if the pressure at A is greater than the pressure at B. In the second position the two ports are disconnected from each other. Activation symbols are added along the sides of the envelope to indicate the method of activating a particular position.

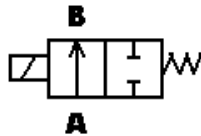

The symbol on L.H.S of the 2/2 valve indicates a solenoid. When the solenoid is energized the valve takes first position connecting ports A and B and when de-energized, disconnects the ports due to the action of the return spring. The above principle is applied to other types of valves like 3 port - 2 position (3/2), 4 port - 3 position (4/3) and 5 port - 3 position (5/3).



Pneumatic cylinders in various bore and stroke length

Pneumatic cylinder - The pneumatic cylinder is an actuator which converts pressure to displacement. When the pressure on one side of the piston is relatively higher than on the other side, it results in a linear displacement. The speed of traversal is proportional to the pressure difference. A double acting cylinder has two ports through which the supply of air is reversed to cause displacement in either direction. The general specification for a pneumatic cylinder is in terms of the bore (diameter) of the cylinder, the stroke length of the piston and the maximum operating pressure range. Cylinders are manufactured in different dimensions for different operating pressure.

Pneumatic designs

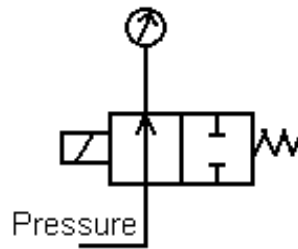

The above diagram shows a simple usage of a 2/2 valve for monitoring the pressure of a system using a pressure gauge. The 2/2 valve is connected to a pressure source and a pressure gauge. When the solenoid is energized, the high-pressure air enters the gauge and the pointer is displaced and measures the value. When the valve is de-energized, the high-pressure line is cut off from the gauge and the pressure variations cannot be measured. But the air between the gauge and port B is trapped, preventing the pointer to return to zero and leaves the last value measured before de-energizing the solenoid.

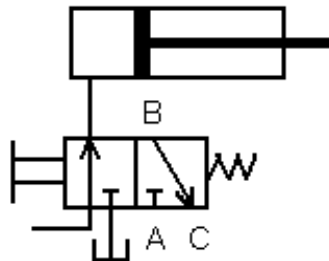

A 3/2 valve is used to control the motion of the piston in the pneumatic cylinder. The valve is manually operated to connect port A and B causing the piston to displace toward the right. Port C is connected to the vent. When the valve is released, due to the return spring action, ports B and C are connected. Air tapped on the other side of the single acting cylinder caused it to return to the original position.

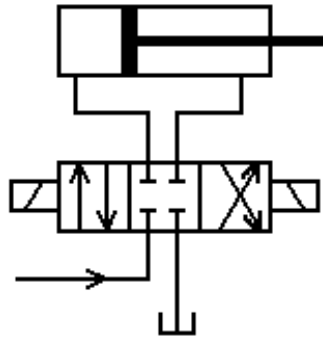

A 4/3 double solenoid valve is used to displace the piston of the double acting cylinder in both the directions. When the solenoid X is energized, the piston travels to the right and when Y is energized, the piston travels to the left. When both the solenoids are de-energized the piston stops.

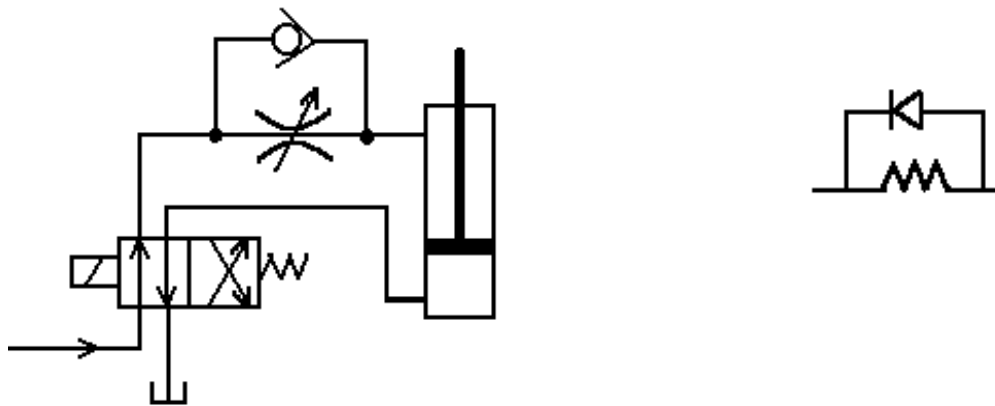

A simple speed control of the actuator is achieved using the above system. The 4/2 DCV is used to reverse the direction of the piston when the solenoid is energized. A check valve is connected across a variable flow control valve. When the piston travels upward the fluid is bypassed through the check valve by displacing the ball and shoots up at high speed. The downward stroke speed is controlled by the settings of the variable flow control valve, which restricts flow when the solenoid is de-energized.

An equivalent electrical circuit for the flow direction is shown.

Sensors



Proximity sensors and optical sensors are manufactured in various sizes and dimensions.

PLC controlled pneumatic systems employ sensors to determine the position, displacement and velocity of actuators and links. Traditional systems use pressure switches, micro switches and limit switches to sense various real time parameters. The venture of microcomputers into the control of pneumatic systems has facilitated the use of non-contact sensors like the proximity, Hall effect and photoelectric sensors. More intelligence was added to the machines and parameters like the temperature and pressure of the fluid at critical points, atmospheric data at the intake (pressure, density and humidity) and lubrication effects were monitored during operation.

Design of a pneumatic system for a drilling machine

A drilling machine is primarily used to originate holes on a work piece and can perform similar operations. Drilling machines are designed in different shapes, types and sizes to handle a class of work or a specific job. Some of the common types are portable drilling machine, gang, radial, multi-spindle and sensitive drilling machine. In general a drilling machine requires a vertical feed at constant rate during material removal and quick - return after the drilling operation.

The cylinder CYL1 generates the vertical motion. The job or work piece should be loaded under the drill bit before the commencement of the operation and pushed away after the completion of the operation, respectively performed by CYL2 and CYL3.

The motion of CYL1 is controlled using the 3/2, 4/2 (single solenoid) and the 4/3 valves (dual solenoid). The four solenoids S1, S2, S3 and S4 can be switched in 16 combinations out of which only four are used for effective control as shown below.

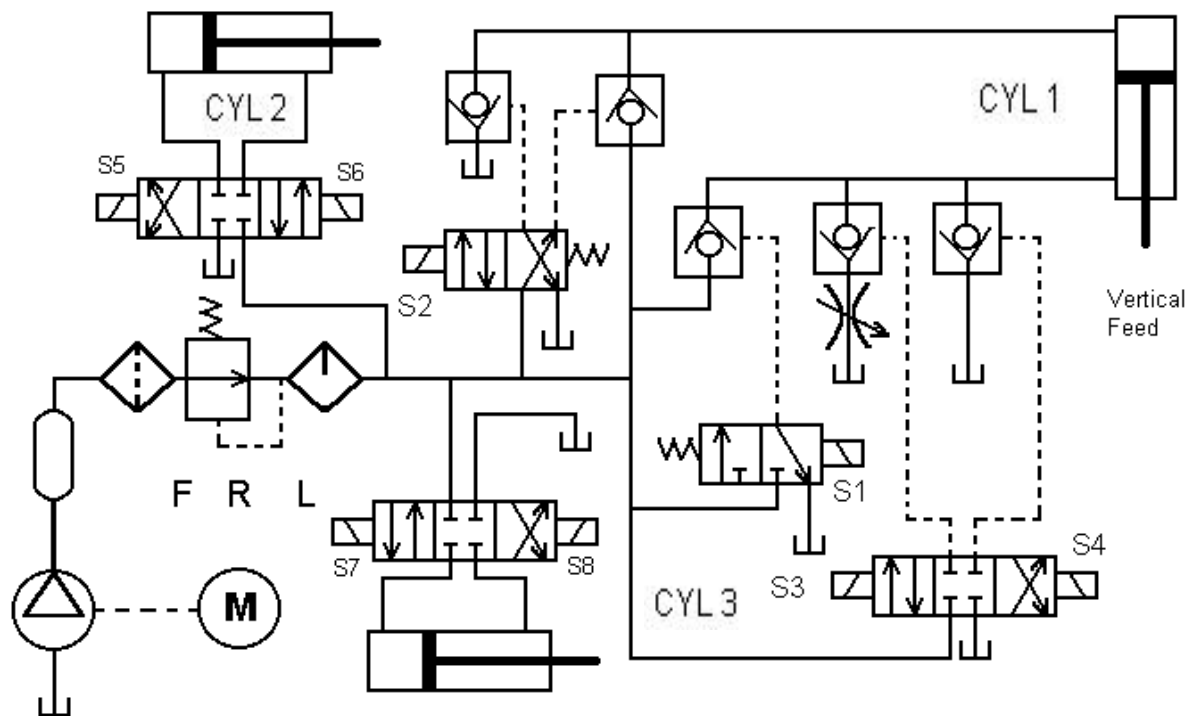

S1	S2	S3	S4	
0	0	0	0	- Piston locked in fixed position.
0	1	0	0	- Rapid traversal in upward direction (quick ret.).
1	0	1	0	- Vertical feed (downward direction).
1	0	0	1	- Rapid traversal in downward direction.

The solenoids S<5:8> are used to control the direction of motion of CYL2 and CYL3.

A microcontroller is used to control the motion of the actuators. The firing of the solenoids are based upon a program stored in the memory of the microcontroller which makes decisions depending upon the data measured by its sensors. All the critical parameters like temperature, pressure, firing sequence and the duration are displayed on a console for monitoring the status of the machine.

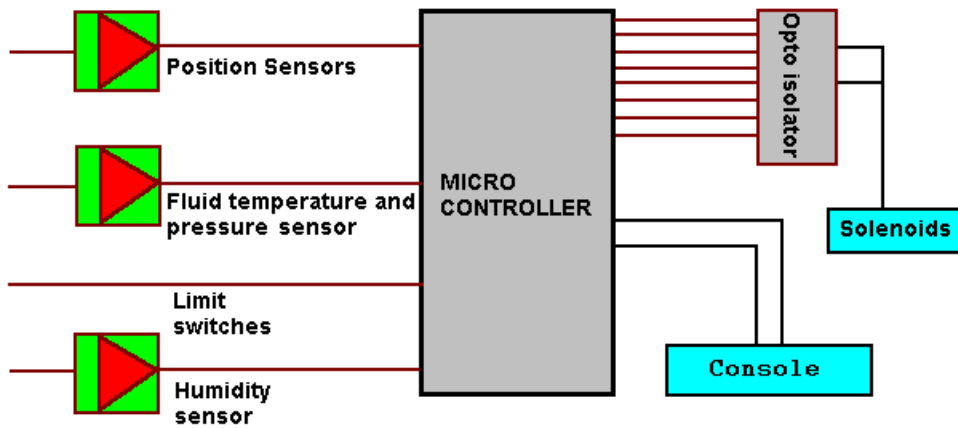

Fluid power systems were once the only form of motion control engineering widely used for a variety of applications. Introduction of electrical actuators like servo and stepper motors, appear to have replaced these rugged systems. Despite the fact that the electrical motors and other electromechanical actuators have reasonable amount of complexity, precision control and miniaturization, they can never outweigh the raw power of a fluid power system which can brutally crush a ton of steel to pieces within seconds, at the same time elegantly handle the glass windshield in an automotive assembly line.

Appendix

